

MCKARLEN

SW - 50Hz



**HORIZONTAL
CENTRIFUGAL
PUMP**

www.mckarlen.com

HORIZONTAL CENTRIFUGAL PUMP - SW

MCKARLEN

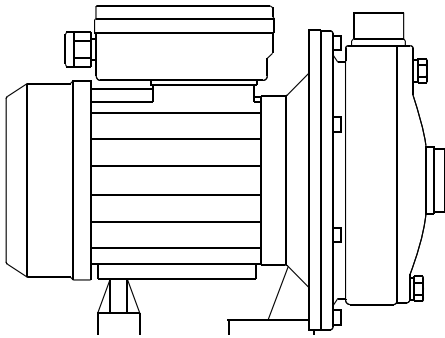
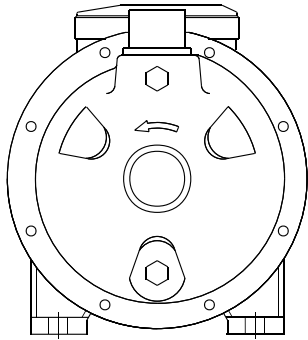

Weight : 11 - 20 kg

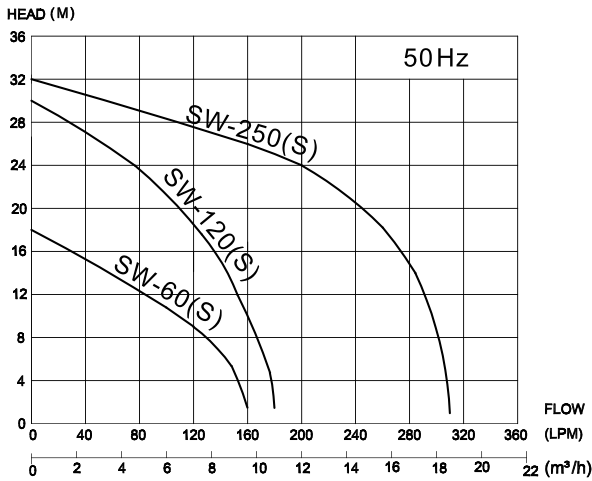

SPECIFICATION

OUTPUT	HEAD	FLOW
0.4 - 1.85 kW	Max : 30 m	Min : 35 l/min Max : 300 l/min

Motor

2 Pole, 50Hz
1 and 3 Phase
Insulation Class B
Protection Type IP55
Speed 2900 / 3450rpm

Pump

Material
Casing : SUS304 (SW type)
SUS316 (SW-S type)
Motor Housing : Aluminium
Shaft : SUS 316
Mechanical Seal : CA/CE (SW type)
Viton (SW-S type)

pH 6 up to 8
Max. liquid temp : 70°C (158°F)
Max. Suction : 8 m

APPLICATION

- Gardening
- Irrigation system
- Domestic Applications
- Domestic System
- Industrial Applications
- Suitable for pumping solar fuel (SW-S type only)

Model	Output		Outlet		Dimension (mm)	Weight (Kg)
	HP	kW	mm	inch		
SW-60	1/2	0.4	25	1	315 x 213 x 218	11
SW-120 (S)	1-1/4	1	25	1	360 x 245 x 275	15.5
SW-250 (S)	2-1/2	1.85	32	1-1/4	366 x 213 x 253	20