

**MCKARLEN**

**HC - 50Hz**



**HORIZONTAL  
CENTRIFUGAL  
PUMP**

# HORIZONTAL CENTRIFUGAL PUMP - HC

# MCKARLEN

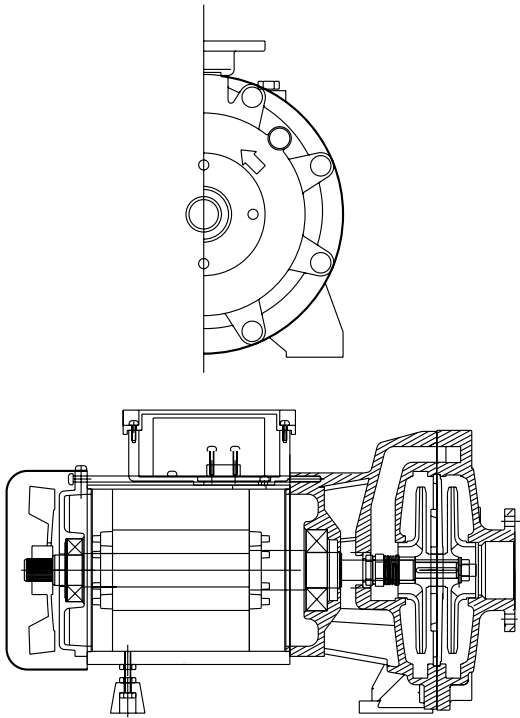

Weight : 54 kg

## SPECIFICATION

OUTPUT	HEAD	FLOW
3 kW	Max : 65 m	Min : 120 l/min
		Max : 270 l/min

### Motor

2 Pole, 50Hz  
 Insulation Class B  
 Protection Type IP44  
 Speed 2900rpm / 3450rpm  
 3 Phase

### Pump

Material  
 Impeller : Bronze  
 Casing : FC200  
 Motor Housing : Aluminium  
 Mechanical Seal : CA/CE  
 pH 6 up to 8  
 Max. liquid temp : 40°C (104°F)

## APPLICATION

- Gardening and springkling
- Irrigation system
- Domestic pump
- Domestic booster
- RO reverse penetration
- Cooling water system

Model	Output		Outlet		Dimension (mm)	Weight (Kg)
	HP	kW	mm	inch		
HC-40	4	3	50	2	536 x 315 x 290	54

Double impeller design. Outlet can be connected to 2" x 1-1/2" reducer

