

MCKARLEN

GP - 50Hz



SEWAGE PUMP WITH AGITATOR



SEWAGE PUMP WITH AGITATOR - GP

MCKARLEN

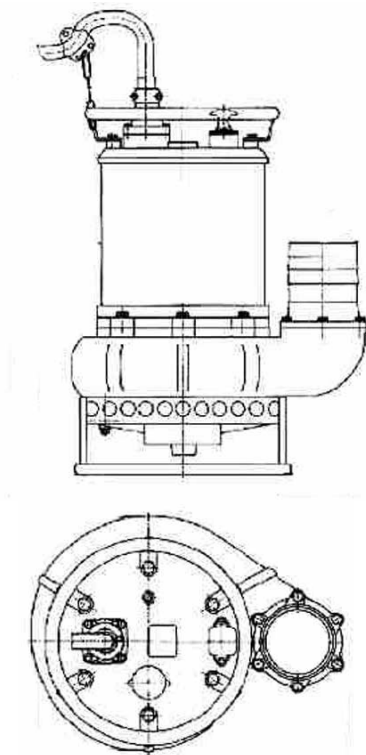

Weight : 230 kg

SPECIFICATION

OUTPUT	HEAD	FLOW
11 kW	Max : 19 m	Max : 3400 l/min

Motor

2 Pole, 50Hz
 Insulation Class F
 3 Phase
 Protection Type IP68
 Speed 2850rpm / 3450rpm

Pump

Material
 Impeller : HCR
 Agitator: HCR
 Casing : FCD450
 Motor Housing : FC200
 Mechanical Seal : SIC/SIC
 Shaft : SUS304J2
 Max. liquid temp : 40°C (104°F)
 Max. depth 10m

APPLICATION

- For sump effluent, waste water & sewage.
- Groundwater lowering.
- General construction & civil engineering application.
- Tunnel & subway construction.
- Municipal pump pits.
- Rain and spring water drainage.

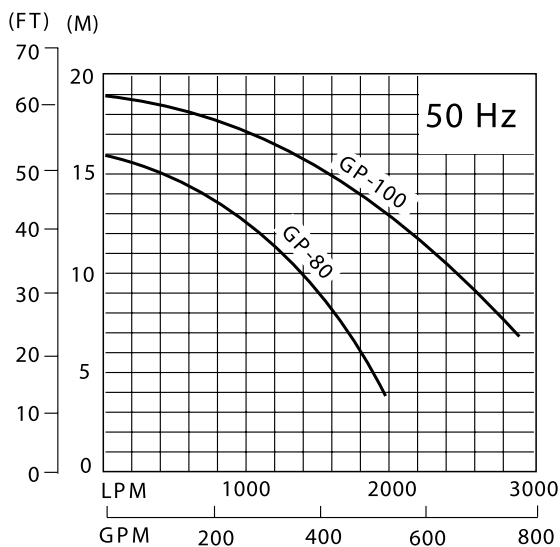

Model	Output		Outlet		Dimension (mm)	Weight (Kg)
	HP	kW	mm	inch		
GP-100	15	11	100	4	637 x 749 x 831	230

Specifications can be changed without notice